



AP Series Horizontal Shaft Impact Crushers

Description

AP 40x30 & AP 40x52

There are two mid-range sizes of AP crusher available for primary, secondary or recycling units. Factory equipped with four bar rotors, they can be converted to two bar machines with the addition of a specialized counterweight system. These crushers are medium duty, and are ideally suited for installation on stationary or portable crushing systems.

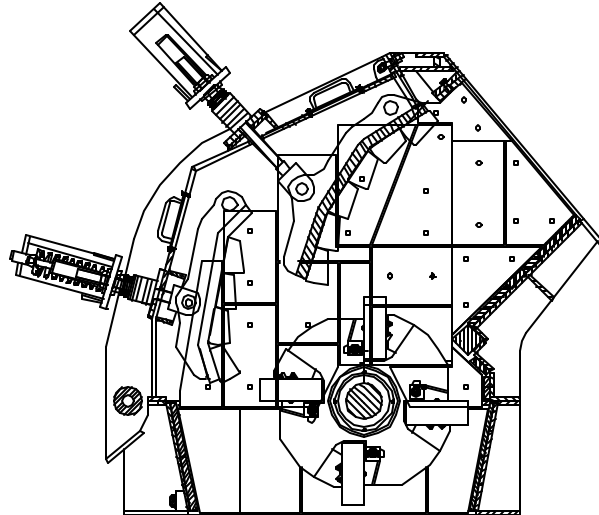

AP 52x60 & AP 52x60 SR

These two larger units are designed for high production primary, secondary, and recycling applications. The standard open rotor design provides sufficient force to handle large feed material. The even heavier SR (solid rotor) units provide all the mass and strength necessary to crush feed material up to 36".

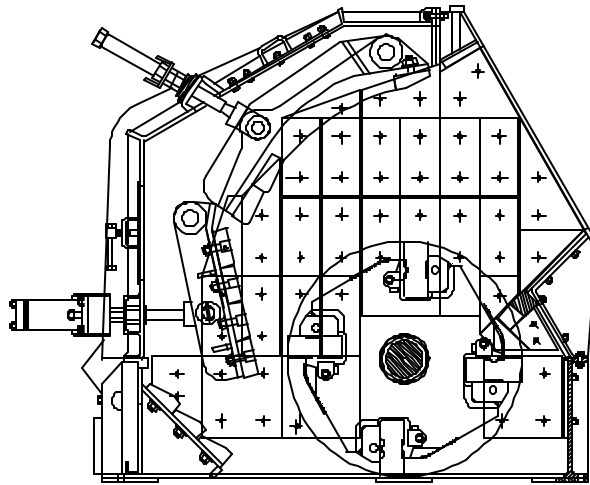

Whichever unit is ultimately selected, these units are each manufactured with heavy duty, high speed spherical bearings and oversized shafts. Those critical components help to ensure a long lasting operating life for the crushers.

All machines use greased bearings. They are also all equipped with hydraulically operated hoods, manually adjusted primary curtains, and hydraulically adjusted secondary curtains. Blow bars are available in manganese, and low, medium, and high chrome steels. We also work with foundries to supply the best wear parts for each particular application.

Applications

- Hard Rock Crushing*
- Mixed Demolition Debris*
- Crushed or Broken Concrete*
- Asphalt*

Models/Sizes

- 40" x 30"*
- 40" x 52"*
- 52" x 60"*
- 52" x 60" Solid Rotor*

Other Considerations

- Quick Deliveries*
- Off-the-shelf parts*
- Nationwide distribution*
- Superior Quality*
- Low Price Guarantee*

Cornerstone Equipment, Inc.

13037 Ottawa Drive Savage, MN 55378-1673

Tel: 952-894-4550 Cell: 612-618-7411

Website: www.crushersales.com Email: hunter@usinternet.com



AP Series Horizontal Shaft Impact Crushers



AP4052 Impact Crusher Installed with 46x16 Feeder in Portable Plant Operating in Midwest United States

Model	Max Production TPH	Max HP / KW	Feed Opening	Machine Weight LB	Blow Bar Rows	Blow Bar Weight LB	Bearings
AP 40x30	120	100	35" (H) x 30" (W)	22,000	2, 3, or 4	430	160
AP 40x52	250	250	35" (H) x 52" (W)	30,000	2, 3, or 4	375	180
AP 52x60	400	350	38" (H) x 60" (W)	44,000	2, 3, or 4	300	190
AP 52x60 SR	400	450	38" (H) x 60" (W)	54,000	2, 3, or 4	300	220



AP 40x52 Impactor



AP 52x60 Impactor



AP 40x30 Impactor