

C Series Jaw Crushers



These well engineered, highly efficient jaw crushers use the most current engineering knowledge available in jaw crusher design.

The units utilize pitched fixed jaw dies, and steeply aligned toggle seats to provide the most efficient nip angles. The resulting geometry yields a highly efficient, and highly productive family of jaw crushers.

The four available sizes, 20x36, 24x36, 30x42, and 30x54 provide mid-range productivity for contractors and producers alike.

All of the models are manufactured with welded frames and fabricated pitmen. Their fixed jaw dies have wrap-around design that protects the frame and eliminates the need for additional wedges. Side tensioning wedges provide a simple method for keeping the dies in the correct operating position. The cheek plates are kept in place through an easy to maintain bolt system.

The crushers are driven by extra large, overhead eccentric shafts seated in spherical, self aligning roller bearings. Like all Trio products, this equipment is backed with the company's standard one-year warranty and continuing service commit-



Applications

Primary and Secondary Hard Rock Crushing

Mixed Demolition Debris

Crushed or Broken Concrete

Asphalt

River Rock

Premium Features

Fabricated, stress relieved steel base

Rib-reinforced side plates

Close-tolerance machined jaw plates and seating surfaces

Reversible jaw plates

Spherical, self aligning roller bearings

Drop-forged, heat treated eccentric shafts

Manual or hydraulic shim closed setting adjustments

Models/Sizes

20x36

24x36

30x42

32x54

Other Considerations

Low Price Guarantee

Minimal Lead Times

Off-the-shelf parts

Nationwide distribution

One Year Replacement Warranty

Cornerstone Equipment, Inc.

13037 Ottawa Drive Savage, MN 55378-1673

Tel: 952.894.4550 Fax: 952.894.1187

www.crushersales.com g.mcnevin@mchsi.com

C Series Jaw Crushers

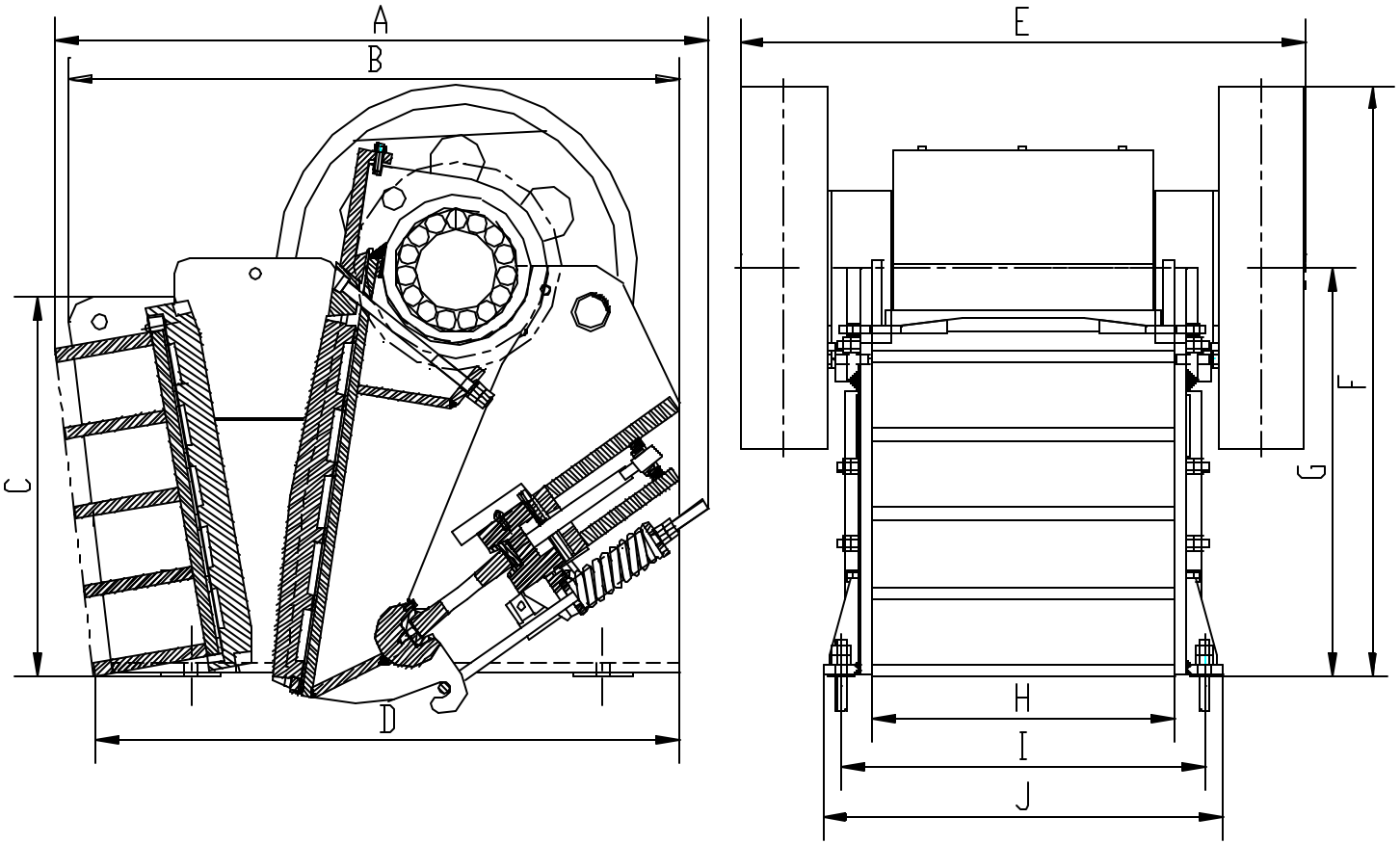

	A	B	C	D	E	F	G	H	I	J
20 x 36	7'-0"	6'-6"	4'-1/2"	6'-3"	6'-1"	6'-4"	4'-4"	3'-3"	3'-11"	4'-3"
24 x 36	7'-9"	7'-4"	5'-1"	6'-11"	6'-3"	7'-11"	5'-5"	3'-3"	4'-0"	4'-7"
30 x 42	8'-11"	8'-6"	6'-2"	8'-0"	7'-3"	9'-1"	6'-4"	3'-9"	4'-10"	5'-8"
32 x 54	8' 7"	8' 7"	5' 8"	8' 7"	8' 11"	9' 3"	5' 7"	4' 9"	5' 7"	6' 2"

	Weight	Discharge Opening	TPH	HP	Frame Bearing	Pitman Bearing	RPM	Fixed Jaw	Swing Jaw
20 x 36	22,500	2" to 4"	60 to 120	75	22244	23148	275	1,480	1,400
24 x 36	28,000	2 3/4" to 5"	100 to 200	100	23148	23152	250	1,500	1,250
30 x 42	53,250	3" to 5 1/2"	150 to 350	200	23168	23172	250	2,950	2,630
32 x 54	65,000	3" to 5 1/2"	235 to 700	250	Call	Call	250	Call	Call

Cornerstone Equipment, Inc.
 13037 Ottawa Drive Savage, MN 55378-1673
 Tel: 952.894.4550 Fax: 952.894.1187
www.crushersales.com g.mcnevin@mchsi.com